

SPECIFICATION & APPROVALS

CUSTOMER:

PowerConnections P/N: ECP

DESCRIPTION: EURO CONVERTER PLUG

DATE: 24 Jun 2019

Revision: J

Submission Sample Quantity: 10 Pieces

Uncontrolled when Copied or Printed

SPECIFICATION & APPROVALS
SUPPLIER SPECIFICATION SUBMISSION

Date of Application	24 Jun 2019	Specification No.	700-0001
Supplier's Name	PowerConnections	Supplier Code Part No	ECP
Part Name	EURO CONVERTER PLUG		

Tick the relevant box "✓"

Reason for Submission

- 1. New application
- 2. New part(s) is added to accepted specification
- 3. Revision of accepted specification

(Revision requested by customer Or supplier)

Revision / Change

- 1. The specification attached to this sheet does not deviate from the customer specification
- 2. Revision(s) within the limits of customer specification is proposed. Revision proposal(s) listed below.
- 3. Revision(s) beyond the limits of customer specification is proposed. Revision proposal(s) listed below. However, all other items contained within the specification are identical to the customer specification.

Revision(s) shall be marked with a triangle "Δ" in the specification attached.

Revision No.	Date	Revision Description	Reason for Revision
A	15-06-04	First issue	
B	08-06-05	New test report added and material changes	Revised for Sony
C	20-01-06	New Certificates	New BSi Certificate
D	25-07-06	Marbo Fuse data added	Alternative fuse available
E	02-07-09	Revised Bussmann fuse	Removal of BSi certification
F	10-05-10	Revised to BS1363-5	Change of applicable standard
G	31-08-10	Base Marking change	Revision of co info
H	11-01-19	Base Marking change and AsiaFuse data added	BS1363 and RoHS Directive updates, and new fuse used

Revision History continues over page

SPECIFICATION & APPROVALS

I	30-05-19	Base marking changed to include WEEE markings	Updates to EU WEEE regulations guidance
J	21-06-19	Safety Specification Approvals - certification details added and links to validate, removed fuses not supplied any more, marking drawing now all black	Alignment with new format for all spec and approval documents

Checked By

--	--	--	--	--

Approved By

Paul M. Lewis Jr.

Uncontrolled when Copied or Printed

Table of Contents

Section	Description	Page
1.0	Application	5
2.0	Name/Part Number	5
3.0	Shape and Dimensions	5
4.0	Rating	5
5.0	Safety Specifications – Approvals	5
6.0	Electrical Strength Test	6
7.0	Mechanical Strength Tests	7
8.0	Construction Tests	8
9.0	Glow Wire Tests	8
10.0	Material Strength Tests	9
11.0	Component Name	10
12.0	Fuse Specification	11
13.0	Installation Procedure	12
14.0	Packing Method	13
15.0	Dimensional Drawing and Markings	14

Uncontrolled when Copied or Printed

PowerConnections		THIS DOCUMENT CONTAINS INFORMATION WHICH IS PROPRIETRY TO POWERCONNECTIONS AND SHOULD NOT BE USED WITHOUT WRITTEN PERMISSION		
TITLE	EURO CONVERTER PLUG	DRAWN BY	CHECKED BY	APPROVED BY
Part No. ECP	SPECIFICATION NO. 700-0001			<i>Paul M. Jones</i>
	REVISION J			

1.0 Application

This Specification defines the performance for the Euro Converter Plug, which is designed for the Euro Plug (CEE7).

2.0 Name/Part Number

Name: EURO CONVERTER PLUG

Part Number: ECP

3.0 Shape and Dimensions

See Below (Section 15)

4.0 Rating

Voltage: AC 240V / 50Hz

Current: 2.5A

Ambient Working Temperature: -5 +70 °C

Storage Temperature: -40 +80 °C 90%RH

5.0 Safety Specifications – Approvals

Plug: BSI Kitemark Licence No. KM 23223

Fuse: ASTA Diamond Mark Licence No.974

Standards

Plug: BS1363-5:2016

Fuse: BS1362:1973 + Amendment 1 & 2

For BSI Kite Mark Licence validation visit <https://www.bsigroup.com/en-GB/Product-Directory/>

For ASTA Diamond Mark Validation visit <http://www.astabeab.com/buyers-by-number.asp>

PowerConnections		THIS DOCUMENT CONTAINS INFORMATION WHICH IS PROPRIETRY TO POWERCONNECTIONS AND SHOULD NOT BE USED WITHOUT WRITTEN PERMISSION		
TITLE	EURO CONVERTER PLUG	DRAWN BY	CHECKED BY	APPROVED BY
Part No. ECP	SPECIFICATION NO. 700-0001			
	REVISION J			

6.0 Electrical Strength Test

No.	Test	Clause in Standard	Result	Description of test 6 pieces are subjected to this series of test
6.1	Provision for cables and Cords	19.1 BS1363-5	Pass	A CEE7 Euro Plug is fitted into an ECP and the CEE7cord is subjected to 25 pulls lasting is with a force of 55N, no more than 2mm of displacement is allowed. The cord is then subjected to the pulling force and at 3750v to ensure no breakdown in connection.
6.2	Resistance to ageing	14.2 BS1363-5	Pass	Samples to be kept in a cabinet for 7 days (168 hours) at 70°C±2°C, then tested for stickiness or greasiness by with dry rough cloth wrapped around a fore-finger, force 5N.
6.3	Insulation resistance	15.1 BS1363-5	Pass	500V DC is applied and after 60s the insulation resistance is checked and must be not less than: a) 5MΩ between parts of opposite polarity, b) 5MΩ between parts of opposite polarity connected together and other insulated parts including the earth..
6.4	Electric Strength	15.1 BS1363-5	Pass	2000V AC 50Hz is applied and after 60s the Voltage drop is checked and must be within 3% RMS of the applied Voltage: a) between live parts of opposite polarity, b) between live parts of opposite polarity connected together and other insulated parts including the earth..

Uncontrolled when

PowerConnections		THIS DOCUMENT CONTAINS INFORMATION WHICH IS PROPRIETRY TO POWERCONNECTIONS AND SHOULD NOT BE USED WITHOUT WRITTEN PERMISSION		
TITLE	EURO CONVERTER PLUG	DRAWN BY	CHECKED BY	APPROVED BY
Part No. ECP	SPECIFICATION NO. 700-0001			
	REVISION J			

SPECIFICATION & APPROVALS

7.0 Mechanical Strength Tests

No.	Test	Clause in Standard	Result	Description of test 4 pieces are subjected to this series of tests
7.1	Tumble Barrel test	20.2 BS1363-5	Pass	The product is subjected singly to 1000-drop test in the apparatus as shown in the (BS 1363-5) standard Figure 17.
7.2	Fuse insertion test	20.3.1 BS1363-5	Pass	A solid stainless steel fuse link is inserted 20 times, to test the strength of the clips.
7.3	Temperature rise test	16 BS1363-5	Pass	Current of 2.75 amps is passed for not less than 4 hours and not greater than 8 hours at 250 volts or until stable, the temperature rise is then measured
7.3.1	Box Ambient	For each sample		20.9°C, 21.0°C, 21.4°C
7.3.2	Line Pin Spacer temp rise	For each sample		2.1K, 2.6K, 2.15K max. temp rise permissible 37K
7.3.3	Neutral Pin Spacer temp rise	For each sample		1.7K, 2.3K, 1.6K max. temp rise permissible 37K
7.3.4	Accessible external surface temp rise	For each sample		0.9K, 1.9K, 1.5K max. temp rise permissible 52K

PowerConnections		THIS DOCUMENT CONTAINS INFORMATION WHICH IS PROPRIETRY TO POWERCONNECTIONS AND SHOULD NOT BE USED WITHOUT WRITTEN PERMISSION		
TITLE	EURO CONVERTER PLUG	DRAWN BY	CHECKED BY	APPROVED BY
Part No. ECP	SPECIFICATION NO. 700-0001			
	REVISION J			

SPECIFICATION & APPROVALS

8.0 Construction Tests

No.	Test	Clause in Standard	Result	Description of test 3 pieces are subjected to this series of tests
8.1	Accessibility to live parts	9.1 BS1363-5	Pass	With the unit assembled as in normal use a probe 12 to BS EN 61032:1998 is supplied with a force of 5N whilst a voltage of 45V is supplied to the live parts via an electrical indicator. No access permissible
8.2	Lid to Base security	12.5 BS1363-5	Pass	With the parts at 70°C±5° C a force of 60N is applied to the cover fixing screw, no damage or impairment of function to have occurred.
8.3	Resistance to Heat	22.2 BS1363-5	Pass	With the parts at 70°C±5° C a force of 20N is applied to the plug in the jaws of the apparatus shown in Figure 23, no damage or impairment of function to have occurred, shown by re-testing insulation resistance and electric strength, and must fit the Figure 5 gauge
8.4	Resistance to Heat	22.3 BS1363-5	Pass	Ball pressure test using the apparatus shown in Figure 24, test temperature at 75°C±5° C, the force of 20N is applied for 60 mins after an initial period of 10 mins. The sample is then cooled by immersion in water at room temp and the indentation caused by the ball measured, this must be less than 2mm in diameter.

9.0 Glow Wire Tests

No.	Test	Clause in Standard	Result	Description of test 3 pieces are subjected to this series of tests
9.1	Resistance to Abnormal Heat	23.2 BS1363-5	Pass	A glow wire of 750°C is applied to all the insulating surfaces there must be no visible flames or glowing or these must extinguish within 30s of removal of the glow wire.

PowerConnections		THIS DOCUMENT CONTAINS INFORMATION WHICH IS PROPRIETRY TO POWERCONNECTIONS AND SHOULD NOT BE USED WITHOUT WRITTEN PERMISSION		
TITLE	EURO CONVERTER PLUG	DRAWN BY	CHECKED BY	APPROVED BY
Part No. ECP	SPECIFICATION NO. 700-0001			
	REVISION J			

SPECIFICATION & APPROVALS

10.0 Material Strength Tests

No.	Test	Clause in Standard	Result	Description of test 3 pieces are subjected to this series of tests
10.1	Construction of plug	12.2 BS1363-5	Pass	Critical dimensions of the plug must not exceed the dimensions given in Figure 4a. Compliance checked using the gauge as shown in Figure 5.
10.2	Flexibility of pins	12.8.11 BS1363-5	Pass	Using the apparatus as shown in Figure 8 pins are tested with force of 4.2 to 4.4N applied 25mm from the engagement face, the pins must not deflect by more than 3°30'. The results on the pins were <1°. After this test the parts are again checked again checked using the Figure 5 gauge.

Uncontrolled when Copied

PowerConnections		THIS DOCUMENT CONTAINS INFORMATION WHICH IS PROPRIETRY TO POWERCONNECTIONS AND SHOULD NOT BE USED WITHOUT WRITTEN PERMISSION		
TITLE	EURO CONVERTER PLUG	DRAWN BY	CHECKED BY	APPROVED BY
Part No. ECP	SPECIFICATION NO. 700-0001			
	REVISION J			

SPECIFICATION & APPROVALS

11.0 Component Name

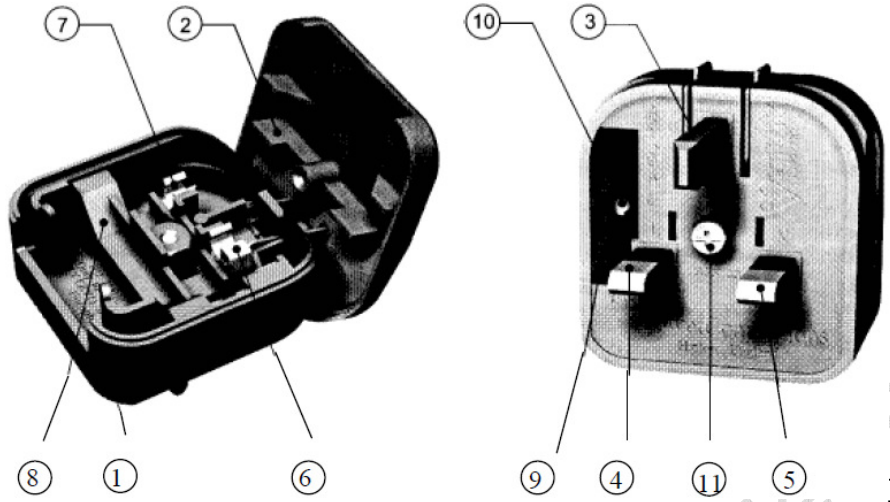



No.	Test	Material
1	Base	Polycarbonate K&J Corporation KP-30
2	Cover	Polycarbonate K&J Corporation KP-30
3	Earth Pin,	Nylon 66 30% Glass Filled Toray CM3004G30
4	Live Pin	Brass (Universal) with Nylon 66 Sleeve JGP Perrite Vitamide AF11BK
5	Neutral Pin	Brass (Universal) with Nylon 66 Sleeve JGP Perrite Vitamide AF11BK
6	Live Clip	Phosphor Bronze Taiwan VPN170-190
7	Neutral Clip	Phosphor Bronze Taiwan VPN170-190
8	Insert	Nylon 66 Sleeve JGP Perrite Vitamide AF11BK
9	Fuse Holder	Nylon 66, JGP Perrite Vitamide AF11BK
10	Fuse	AsiaFuse (Better Fuse) 3A, 5A (BS1362,ASTA)
11	Screw	Plain or Tamperproof Steel Screw with Zinc and Clear Pacification – Golden Metal

PowerConnections		THIS DOCUMENT CONTAINS INFORMATION WHICH IS PROPRIETRY TO POWERCONNECTIONS AND SHOULD NOT BE USED WITHOUT WRITTEN PERMISSION		
TITLE	EURO CONVERTER PLUG	DRAWN BY	CHECKED BY	APPROVED BY
Part No. ECP	SPECIFICATION NO. 700-0001			<i>Paul M. Jones</i>
	REVISION J			

12.0 Fuse Specification

BETTER FUSE/ASIA FUSE

AsiaFuse	Brand Name: AsiaFuse
AF63-13A	Product code: 3 A = AF63B-3A 5 A = AF63B-5A 10 A = AF63C-10A 13 A = AF63-13A
13A	
BS1362	
SS157	
 	Standard: BS1362

Dimensions (units: mm)

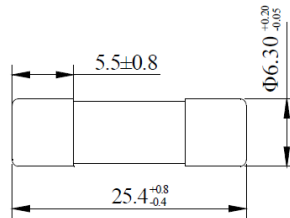

Operating Temperature:

-55°C to 125°C

Storage Conditions:

+10°C to +60°C

Relative humidity: ≤ 75% yearly average
without dew, maximum 30 days at 95%

Vibration Resistance:



24 cycles at 15 min. each (60068-6)

10-60Hz at 0.75mm amplitude

60-2000Hz at 10g acceleration

Electrical characteristics

Electrical Characteristics									
Amp Code	Rated Current	Max. Voltage	Breaking Capacity	Nominal Melting I ² t(A ² sec)	Max. Power Dissipation	Color	Approvals		
							CCC	PSB	ASTA
1100	1A	264V AC	6kA@ 264V AC 50Hz P.f.0.3-0.4	1.44	1W	black	●	○	○
1200	2A			8.73		black	○	○	○
1300	3A			29.16		red	●	●	●
1500	5A			144		black	●	●	●
1700	7A			146.4		black	○	○	●
2100	10A			324		black	●	●	●
2130	13A			961		brown	●	●	●

		THIS DOCUMENT CONTAINS INFORMATION WHICH IS PROPRIETRY TO POWERCONNECTIONS AND SHOULD NOT BE USED WITHOUT WRITTEN PERMISSION		
TITLE	EURO CONVERTER PLUG	DRAWN BY	CHECKED BY	APPROVED BY
Part No. ECP	SPECIFICATION NO. 700-0001			
	REVISION J			

13.0 Installation Procedure

13.0 Installation Procedure

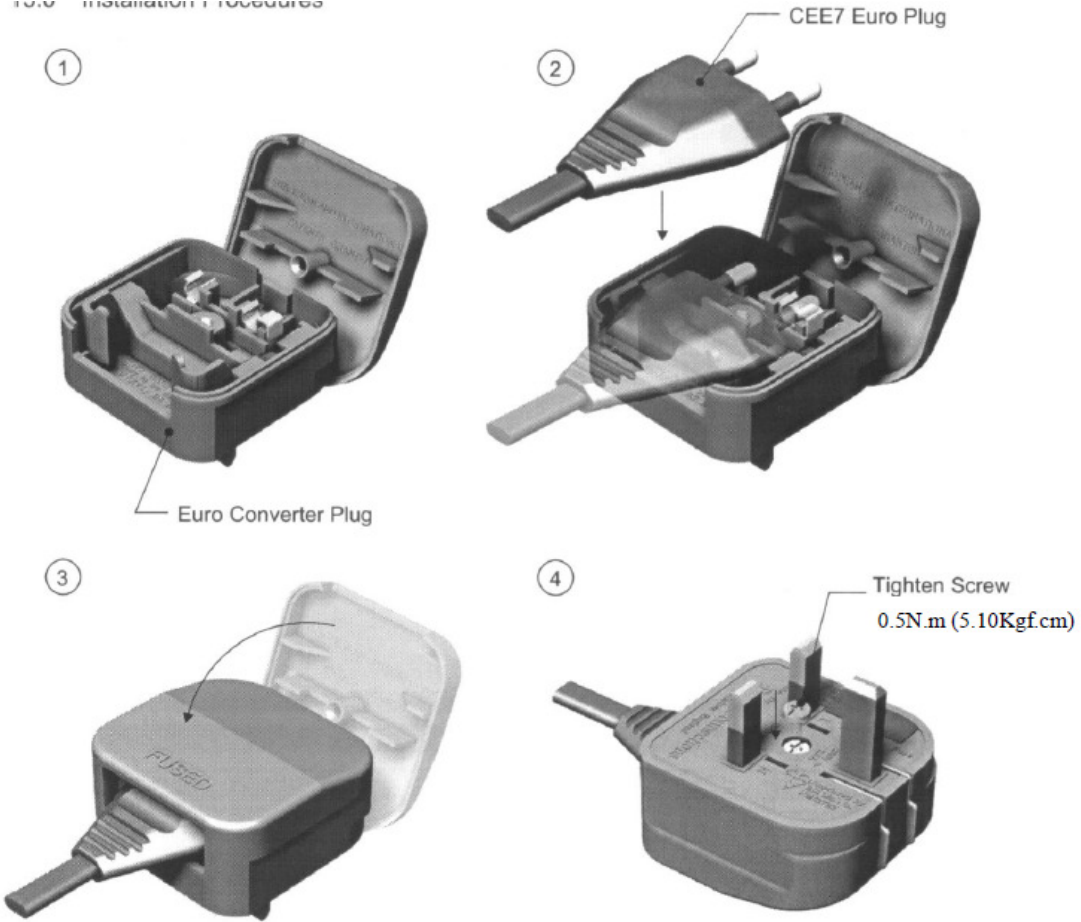

Caution
It is the responsibility of the installer to ensure that the CEE7 plug chosen fits correctly and the provisions in the test for electrical strength 6.1 BS1363-5 Clause 15.1

Unclassified

PowerConnections		THIS DOCUMENT CONTAINS INFORMATION WHICH IS PROPRIETARY TO POWERCONNECTIONS AND SHOULD NOT BE USED WITHOUT WRITTEN PERMISSION		
TITLE	EURO CONVERTER PLUG	DRAWN BY	CHECKED BY	APPROVED BY
Part No. ECP	SPECIFICATION NO. 700-0001			<i>Paul M. Jones</i>
	REVISION J			

14.0 Packing Method

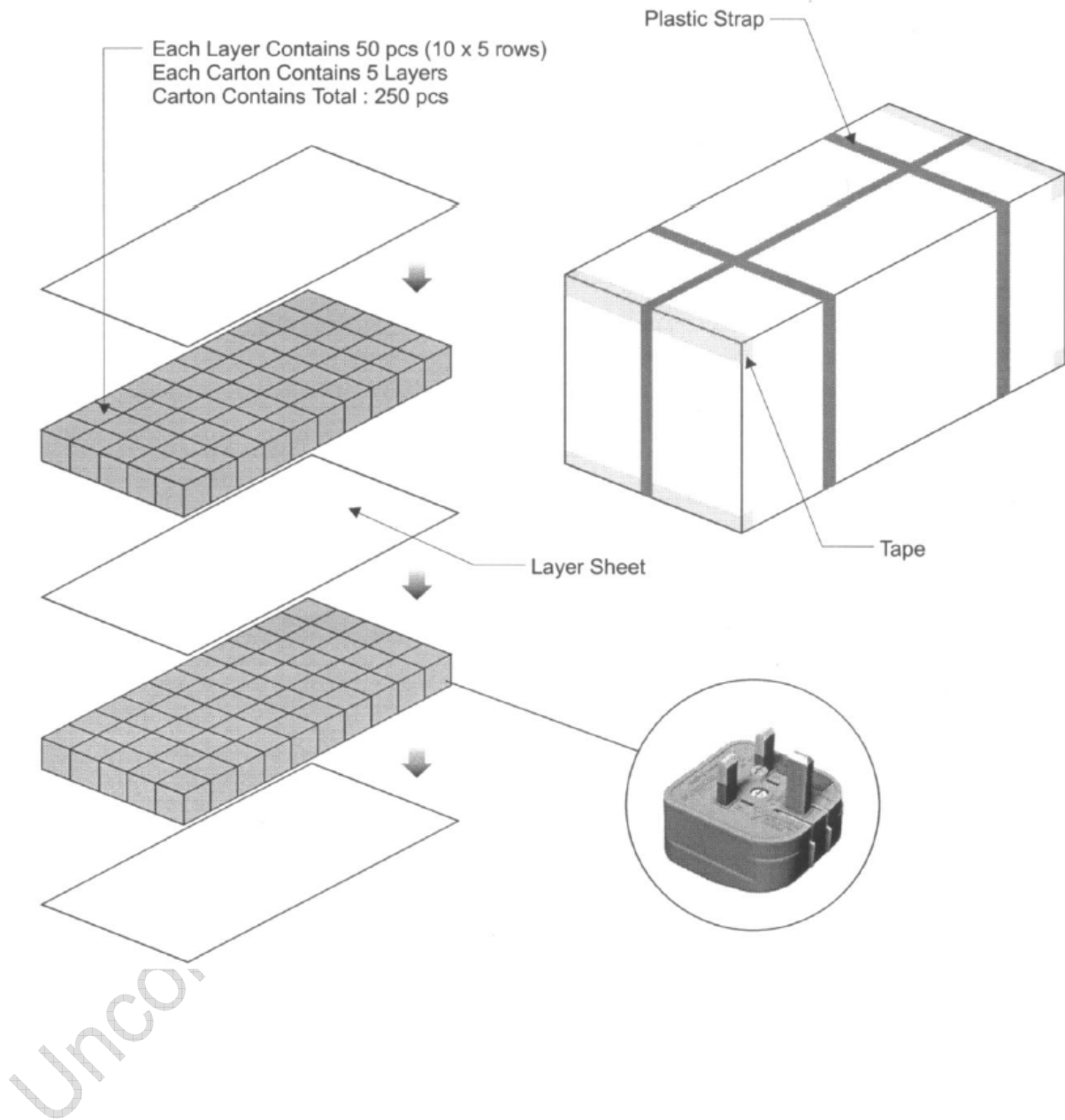

PowerConnections		THIS DOCUMENT CONTAINS INFORMATION WHICH IS PROPRIETRY TO POWERCONNECTIONS AND SHOULD NOT BE USED WITHOUT WRITTEN PERMISSION		
TITLE	EURO CONVERTER PLUG	DRAWN BY	CHECKED BY	APPROVED BY
Part No. ECP	SPECIFICATION NO. 700-0001			<i>Paul M. ...</i>
	REVISION J			

15.0 Dimensional Drawing and Markings

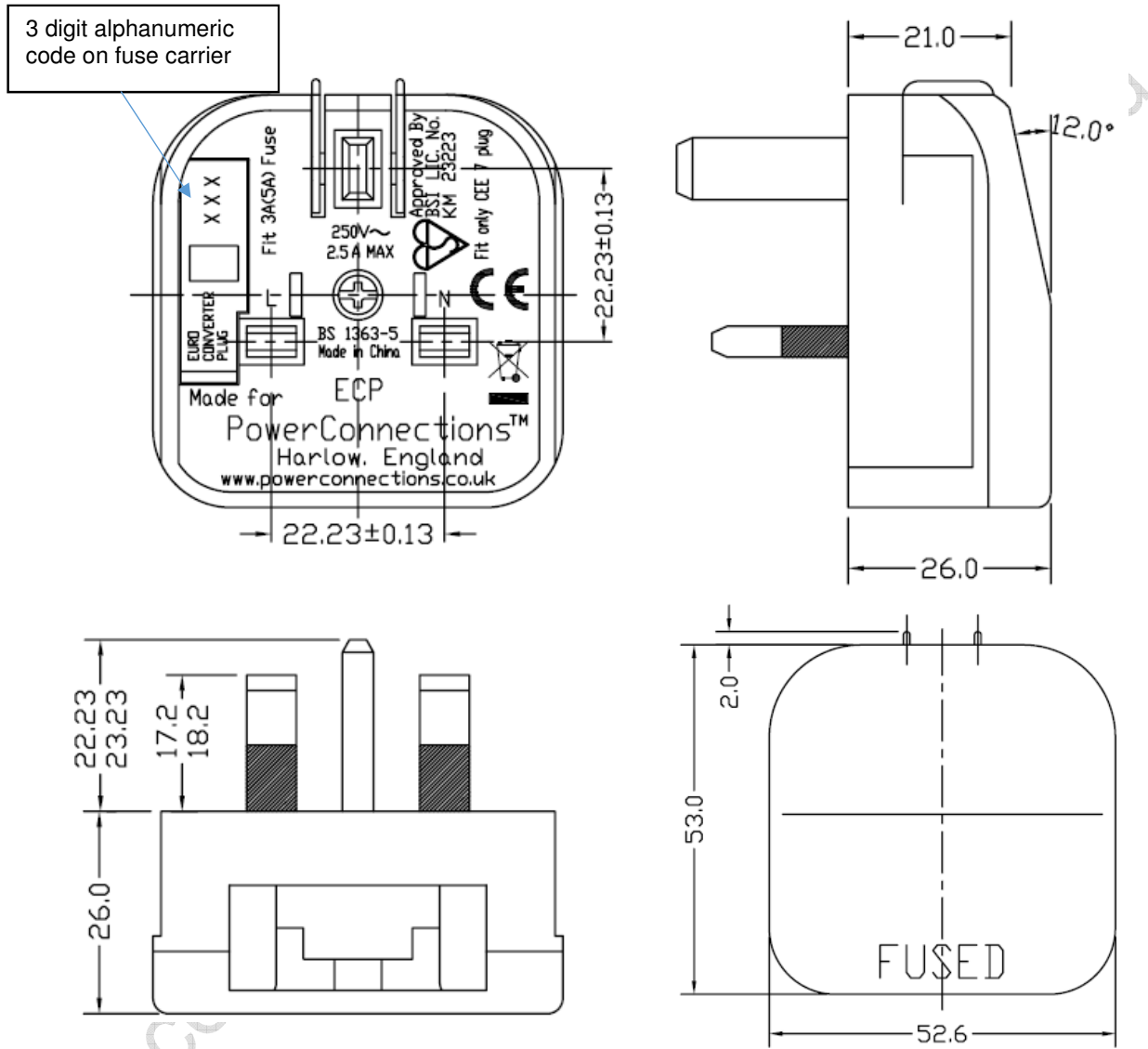

Unclassified

PowerConnections		DO NOT SCALE FROM DRAWING Unless otherwise stated dimensions are mm	
TITLE	EURO CONVERTER PLUG	0	± 0.4
Part No. ECP	SPECIFICATION NO. 700-0001	0.0	± 0.4
	REVISION J	0.00	± 0.1
THIS DOCUMENT CONTAINS INFORMATION WHICH IS PROPRIETRY TO POWERCONNECTIONS AND SHOULD NOT BE USED WITHOUT WRITTEN PERMISSION		DRAWN BY	CHECKED BY
		APPROVED BY <i>Paul M. Lane</i>	